



# ESS

## Electrim Soft Starter





# ABOUT ELECTRIM

---

Electrim series of products cover mainly the MV & LV electrical motors, inverters and starter panels including industries gears & drives.

The company is committed to challenge itself to become a main player in this field. Through the years, we have maintained a policy of providing high performance products and in line with technology development.



## **THE MISSION**

To ensure Products recognition and best status in our Market, the Company emphasize QUALITY over PRICES. We would rather explain our pricing for a while than to apologize QUALITY for a LIFE.

Thus we choose to build a BRAND for long term and not to make short term PROFIT.

Electrim offer a total system solution consisting of motors, starter & protection, inverters & gears box for the industries.

### Product summary

ESS Electrim soft starter is a low voltage bypass type motor start-stop and protection product launched by Rui Neng based on the latest motor control theory and rich experience in industry applications. This product is rich in functions, easy to use, safe and reliable. It is an ideal replacement for motor step-down starting equipment such as star/delta conversion, auto-coupling step-down, magnetic control step-down, etc. It can be widely used in loads such as fans, water pumps, compressors, crushers, etc.

### Common features

#### ■ Applicable power supply

- Wide power supply range suitable for generators
- 380~480V (-15%~+10%)
- 50Hz or 60Hz

#### ■ Wiring and Start

- With factory settings, ESS is ready to start
- Wiring is very simple

#### ■ More convenient design

- The control terminal is located at the top of the product, which can effectively reduce the bending time of wiring personnel and protect the health of frontline workers.
- Clear and comprehensive markings can complete the electrical connection of the control circuit without the installation manual. Or you can check the control wiring through the clear front marking.



External/Built-in/online bypass type control terminal

#### ■ Low Stress/Loss

ESS intelligent Chinese display soft starter can continuously improve the running condition of the motor in the following ways:

- Adaptive soft start control technology is adopted (closed-loop adaptive control of SCR triggering according to power factor to achieve smooth torque-free oscillation starting effect, reduce stress, and extend the life of load equipment). The motor speed curve can be smooth, continuous and monotonically rising in any state without speed inflection point.
- Reduce mechanical and hydraulic stress
- Reduce the load of the distribution system (voltage peak, overcurrent)
- Limit energy loss and temperature rise, etc.



## ■ Friendly human-machine interface

- Large screen English operation panel, clear display interface, convenient for on-site operators to set up and observe.
- Chinese panel is available.
- Standard detachable operation panel, which can be installed on the control cabinet door, can be easily queried operation status information or change setting parameters without stopping the machine.



## ■ Reliable design

- Complete motor protection function  
Such as overload, overcurrent, high current, overvoltage, undervoltage, phase loss and thyristor damage, it can cope with various abnormal conditions of the power grid and load to ensure the reliable operation of the motor.

- Control panel with protective coating  
It can effectively resist dust, moisture and corrosive gases, significantly extending its service life.

## ■ Remote control and data transmission

- Standard RS485 Modbus communication port
- Communication function is used for remote control, monitoring and adjustment
- Through RS485 standard interface, it can be connected to hosts such as personal computers and PLCs
- Function code data of multiple soft starters can be written at one time, and stored

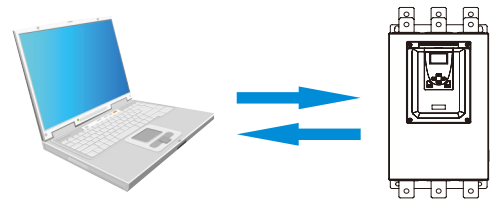

Data transfer between PC and soft starter is easier

## ■ More excellent quality

- Excellent performance, comparable to imported advanced brands in performance and quality
- The listed functions and performance indicators are carefully designed and strictly tested
- All levels of protection
- Easy to install and integrate in the control system
- Guaranteed optimal starting performance under any conditions
- Excellent electromagnetic compatibility

## ■ Standard and Certification

- CCC certification
- Complies with GB/T 14048.6-2016 standard

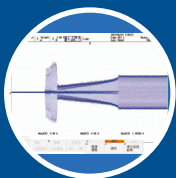

## Multi-mode start

### • Current limited starting mode

- During the starting process, keep the motor current no greater than the set current limit value
- This mode is generally used in situations where there are strict requirements for starting current limits

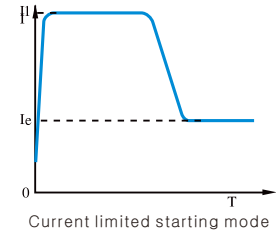

### • Current ramp starting mode

- In this mode, it has strong acceleration capability and can shorten the starting time within a certain range.
- Applicable to two-pole motors

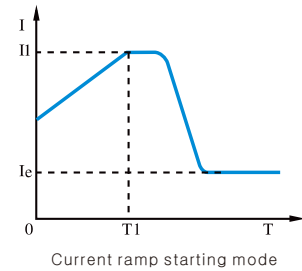

### • Voltage ramp starting mode

- When the motor starts in this mode, the motor current will not exceed 400% of the rated value.
- Applicable to occasions with high requirements for starting stability.

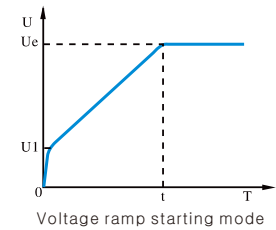

### • Sudden Jump starting mode

- It can overcome mechanical static friction and start the motor easily.
- After the motor starts to rotate, you can freely choose to start it in current limiting mode or voltage ramp mode.

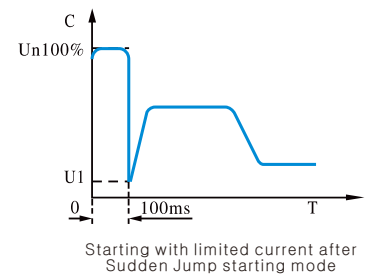

### • Ramp + current limiting start mode

- The output voltage waveform will change according to the motor and load conditions.
- This starting method is mainly used for loads with small power supply capacity and requiring small starting impact.

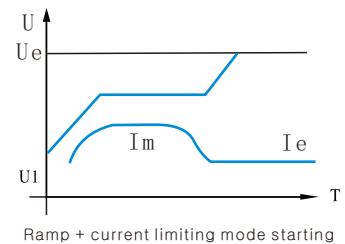

## Multi-industry applications

Suitable for applications such as centrifuges, air compressors, bucket wheel stackers, refrigerators, pulpers, grass cutters, belt conveyors, crushers and circulating water pumps.



Centrifuge, air compressor, bucket wheel stacker reclaimer...

- Limits current and voltage drop during starting
- Smooth starting to prevent overstressing of the drive chain
- Independently adjusts according to load conditions



Compressors, refrigeration machines...

- Even when the starting torque is high, smooth acceleration can be maintained until the rated speed is reached
- Reduce current peak
- Also provides protection for special motors

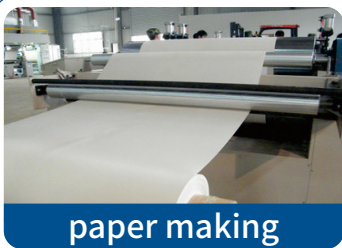

Pulper, grass shredder...

- Provides braking torque when stopped
- Detects overload due to blockage, detects underload



Steel truck, bucket wheel stacker and reclaimer...

- It can reduce a series of problems such as large mechanical and electrical shocks in traditional starting methods, which can easily cause damage to the bucket wheel coupling, high-speed shaft, reducer and other parts.



Belt conveyor, crusher, circulating water pump...

- Progressive starting eliminates impact and belt slippage
- Detects faults, stalls, and underloads
- Plays a role in soft starting and soft stopping in circulating water pumps, reduces water hammer damage, and reduces transformer capacity.

# Model description

ESS   -   T3   -   XXX   -   X  
 ①                      ②                      ③                      ④

① Product Series ESS: Electrim Soft Starter	② Supply Voltage S2: single-phase 220V T3: Three-phase 380V	③ Adapted motor power	④ Unit Bypass External bypass: E Internal bypass: I Online bypass: O
--	---	-----------------------	---

Adaptive motor power (kW)	Rated output current (A)	ESS External bypass type		ESS Built-In bypass type		ESS Online bypass type	
		Soft starter Model (380V)	Dimensions Drawing No.	Soft starter Model (380V)	Dimensions Drawing No.	Soft starter Model (380V)	Dimensions Drawing No.
5.5	11	ESS-T3-5-E	A-1	ESS-T3-5-I	B-1	ESS-T3-5-O	C-1
7.5	15	ESS-T3-7-E		ESS-T3-7-I		ESS-T3-7-O	
11	23	ESS-T3-11-E		ESS-T3-11-I		ESS-T3-11-O	
15	30	ESS-T3-15-E		ESS-T3-15-I		ESS-T3-15-O	
18.5	37	ESS-T3-18-E		ESS-T3-18-I		ESS-T3-18-O	
22	45	ESS-T3-22-E		ESS-T3-22-I		ESS-T3-22-O	
30	60	ESS-T3-30-E		ESS-T3-30-I		ESS-T3-30-O	
37	75	ESS-T3-37-E		ESS-T3-37-I		ESS-T3-37-O	
45	90	ESS-T3-45-E		ESS-T3-45-I		ESS-T3-45-O	
55	110	ESS-T3-55-E		ESS-T3-55-I		ESS-T3-55-O	
75	150	ESS-T3-75-E	A-2	ESS-T3-75-I	B-2	ESS-T3-75-O	C-2
90	180	ESS-T3-90-E		ESS-T3-90-I		ESS-T3-90-O	
115	230	ESS-T3-110-E		ESS-T3-110-I		ESS-T3-110-O	
132	264	ESS-T3-132-E	A-3	ESS-T3-132-I	B-3	ESS-T3-132-O	C-3
160	320	ESS-T3-160-E		ESS-T3-160-I		ESS-T3-160-O	
185	370	ESS-T3-185-E		ESS-T3-185-I		ESS-T3-185-O	
200	400	ESS-T3-200-E		ESS-T3-200-I		ESS-T3-200-O	
250	500	ESS-T3-250-E	A-4	ESS-T3-250-I	B-4	ESS-T3-250-O	C-4
280	560	ESS-T3-280-E		ESS-T3-280-I		ESS-T3-280-O	
320	640	ESS-T3-320-E		ESS-T3-320-I		ESS-T3-320-O	
400	800	ESS-T3-400-E	A-5				
450	900	ESS-T3-450-E					
500	1000	ESS-T3-500-E					

Note: For the external dimensions, installation dimensions and apertures of the ESS series products, please refer to the external dimensions drawing according to the corresponding legend numbers.

# Dimensions Drawing

## ■ ESS External bypass type (ESS-E)

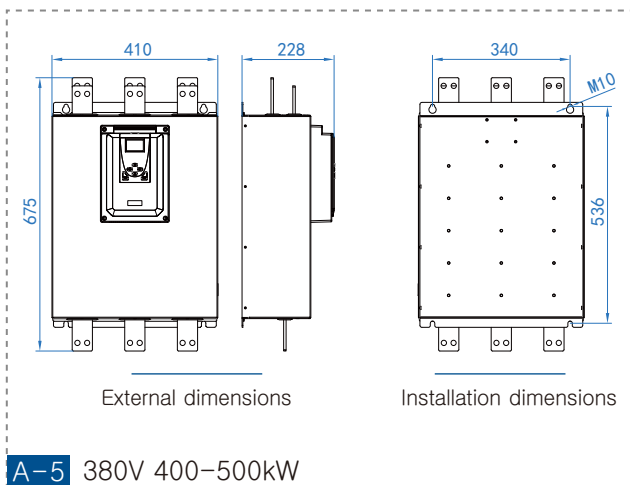
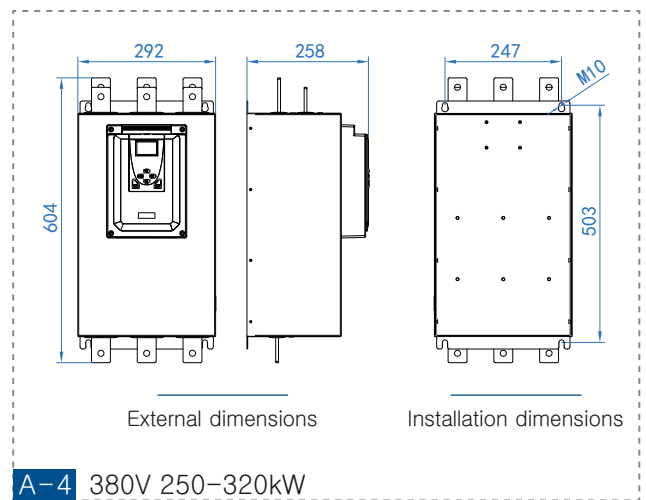
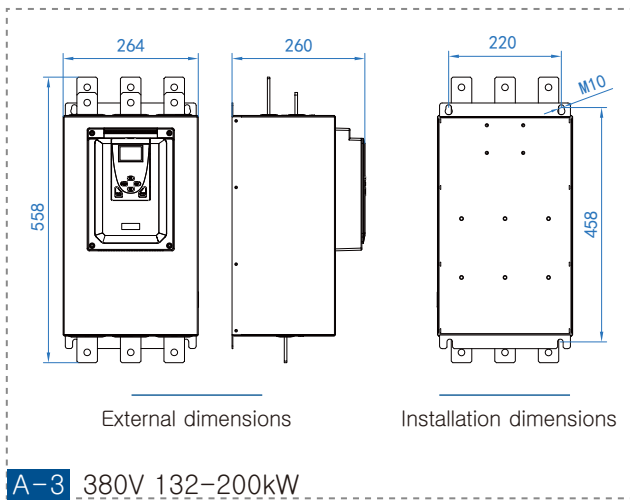
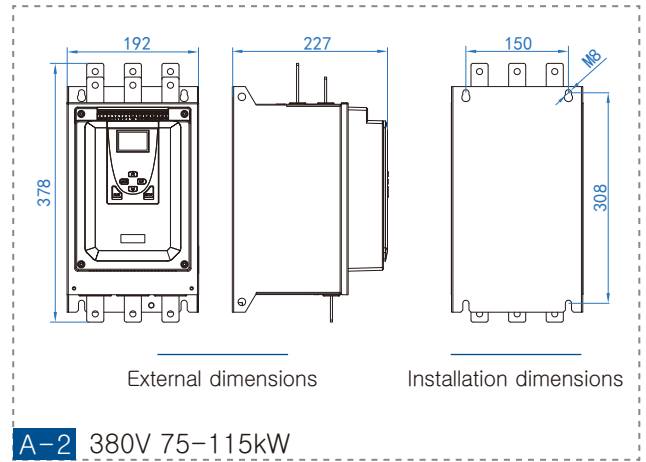
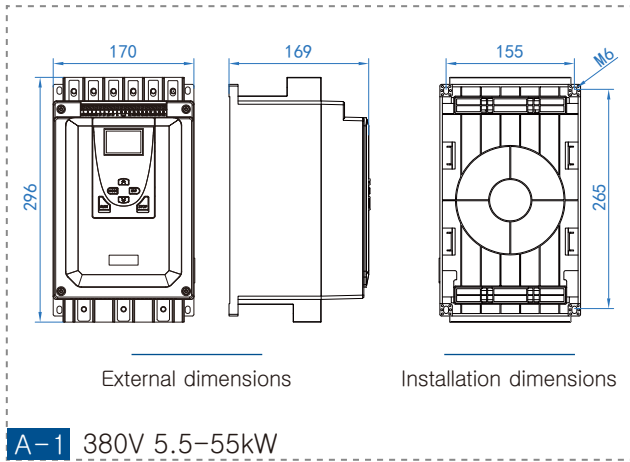

# Dimensions Drawing

## ESS Internal bypass type (ESS-I)

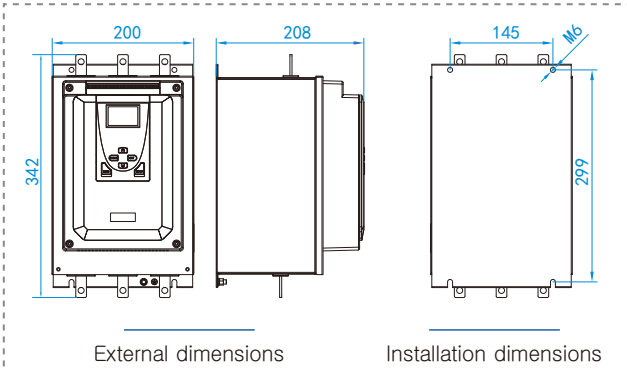

**B-1** 380V 5.5-55kW

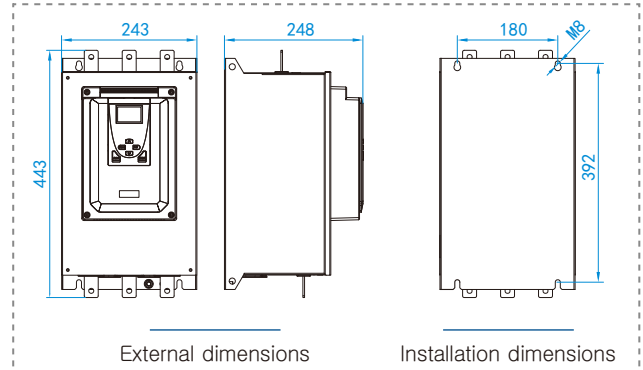

**B-2** 380V 75-115kW

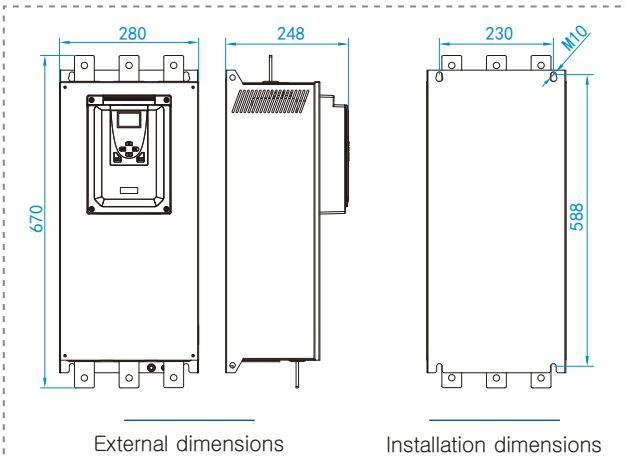

**B-3** 380V 132-200kW

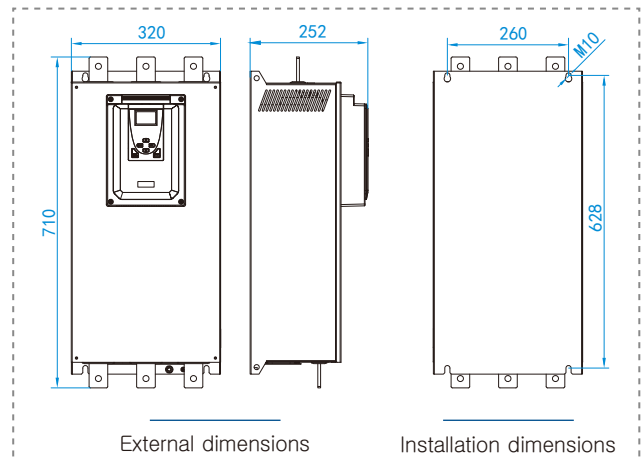

**B-4** 380V 250-320kW

## ESS Online Bypass (ESS-O)

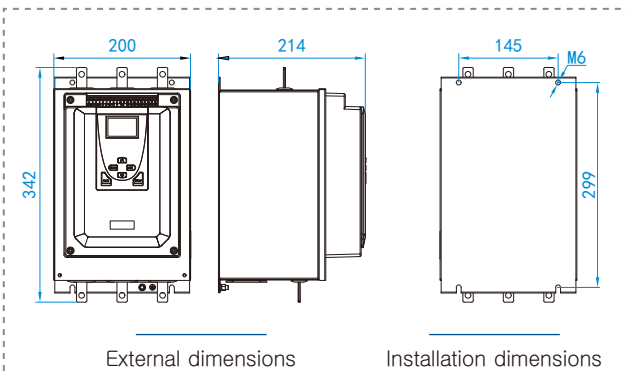

**C-1** 380V 5.5-55kW

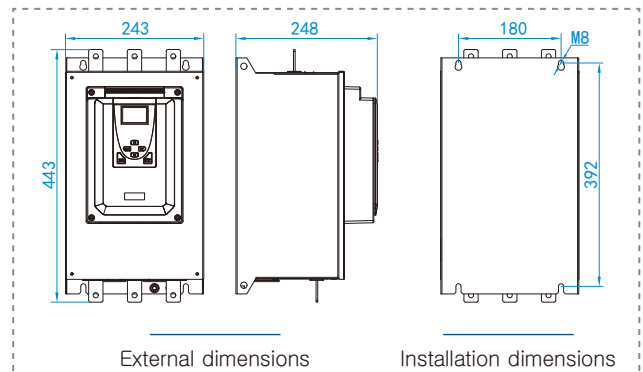

**C-2** 380V 75-115kW

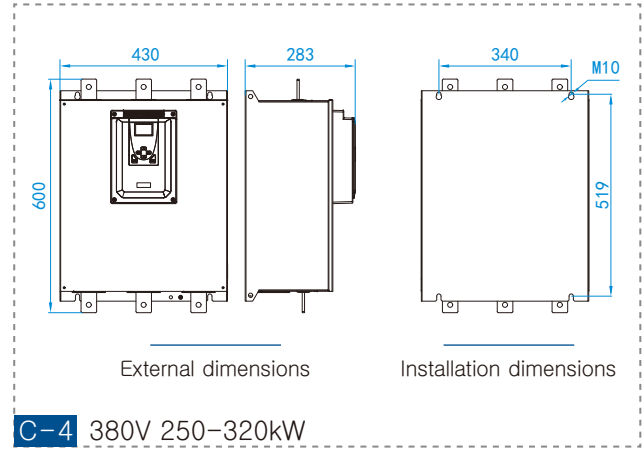
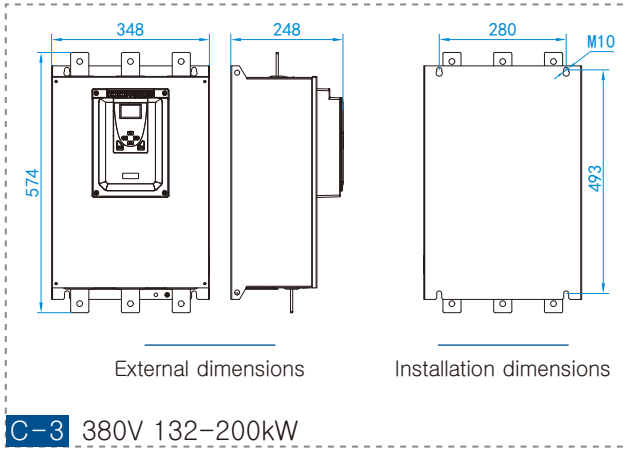

## Panel size

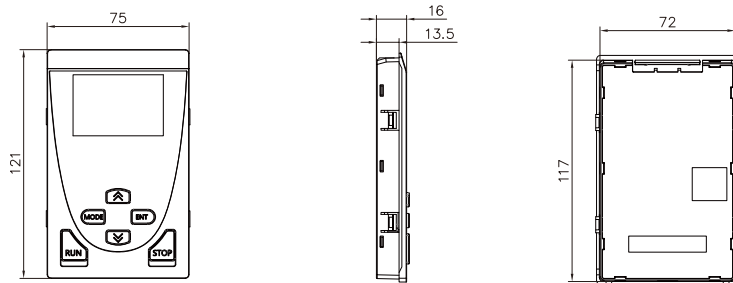

Note: The recommended panel opening size is 118\*72.5mm

## Installation considerations

### Installation Recommendations

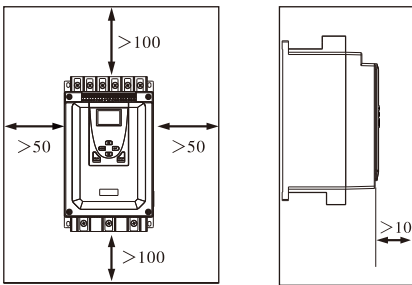

Unit in the figure: millimeter (mm)

- The soft starter should be installed vertically.
- Leave enough heat dissipation space around the equipment to ensure that the air required for cooling circulates from the bottom to the top of the component.
- Do not place the ESS close to or on the heat generating components.

### Installation in a wall-mounted or floor-standing metal enclosure

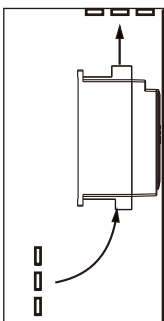

- Meet the above installation requirements
- Select cabinets with good ventilation at the top and bottom
- Install ventilation grids to ensure adequate ventilation

## Performance & configuration

### ESS External bypass type (ESS-E)

Electrical Characteristics	Rated operating voltage	3-phase (380~480)V (-15%~+10%)
	Rated operating frequency	50Hz or 60Hz (please specify in advance before ordering)
	Number of controlled phases	3
	Applicable motor	Squirrel cage three-phase induction motor/asynchronous motor
	Starting frequency	Depending on the load conditions, it is recommended to start and stop no more than 10 times per hour under normal conditions, and 6 times per hour under heavy load
	Starting mode	Voltage ramp, current ramp, current limit, inching, voltage ramp + current limit, sudden jump + voltage ramp
	Stop mode	Free stop, soft stop
	Protection function	Phase loss protection, overcurrent protection, overload protection, current imbalance protection, overheating protection, start timeout protection, etc.
Environmental Characteristics	Operating temperature	-10℃ ~ 40℃ (40℃ ~ 60℃ need to reduce capacity)
	Storage temperature	-25℃ ~ 70℃
	Relative humidity	95% no condensation or dripping
	Altitude	Below 1000m (1000~3000m need to reduce capacity)
	Cooling method	Natural air cooling
	Installation method	Wall-mounted
	Other	No flammable, explosive, corrosive gas, no conductive dust or metal powder
Standard and Certification	Implementation standards	GB/T 14048.6
	Certification	CCC

### ESS Built-In/Online bypass type (ESS-I/ESS-O)

Electrical Characteristics	Rated control power supply	1-phase 220VAC±15%, 50/60Hz
	Rated power supply voltage	3-phase (380~480)V (-15%~+10%)
	Rated power supply frequency	50Hz or 60Hz
	Number of controlled phases	3
	Applicable motor	Squirrel cage three-phase induction motor/asynchronous motor
	Starting frequency	Depends on the load conditions. It is recommended to start and stop no more than 10 times per hour under normal conditions and 6 times per hour under heavy load
	Starting mode	Voltage ramp, current ramp, current limit, inching, voltage ramp + current limit, sudden jump + voltage ramp
	Stop mode	Free stop, soft stop
	Protection function	Phase loss protection, overcurrent protection, overload protection, current imbalance protection, overheating protection, start timeout protection, undervoltage/overvoltage protection, start overfrequency protection, high current protection, thyristor breakdown protection, power reverse sequence protection, wiring error protection, etc.
Environmental Characteristics	Operating temperature	-10℃ ~ 40℃ (40℃ ~ 60℃ need to reduce capacity)
	Storage temperature	-25℃ ~ 70℃
	Relative humidity	95% no condensation or dripping
	Altitude	Below 1000m (1000~3000m need to reduce capacity)
	Cooling method	ESS-I: 55kW and below: natural cooling; 75kW and above: forced air cooling ESS-O: forced air cooling
	Installation method	Wall-mounted
	Other	No flammable, explosive, or corrosive gases, no conductive dust or metal powder
Standard and Certification	Implementation standards	GB/T 14048.6
	Certification	CCC

## Characteristics of each bypass type of ESS series

### ■ ESS External bypass type (ESS-E)



Small size and low cost



After starting, switch to bypass contactor, low energy consumption



High reliability



Easy maintenance in the future

#### Direct connection for simplified wiring

- Complete motor protection function
- No matter where the contactor is located in the cabinet, it can be easily wired

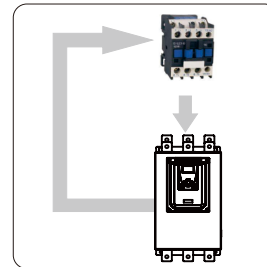
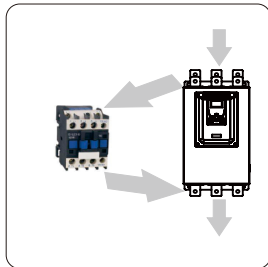

## ■ ESS Internal bypass type (ESS-I)



Energy consumption lower



High comprehensive cost performance



Password protection



Independent control power supply (220VAC), parameter setting is possible even without power supply (380V)



Supports internal motor connection, suitable for larger size motors

Without any other external equipment, one internal soft starter can realize all functions such as soft start, operation, soft stop, etc.

- Cost saving: no need to purchase additional bypass contactors and bypass cables
- Time saving: only 6 power cables need to be connected, RST, UVW, and wiring is simple and convenient
- Space saving: no external bypass contactors, and the overall space required is small

### Start-up adaptive control technology

The triggering of SCR is controlled in a closed loop according to the power factor to achieve a smooth torque-free oscillation starting effect, reduce stress and extend the life of the load equipment.



## ■ ESS Online Bypass (ESS-O)



Independent control power supply (220VAC), parameter setting is possible even without power supply (380V)



After the bypass contactor is removed, there is no limit on the mechanical life of the contactor contacts, and the service life is longer.



Compatible with external contactors, more flexible to use and suitable for a wider range of applications



Can drive non-traditional motor loads such as motor heaters, resistive loads and transformer loads



It can perfectly replace solid-state contactors and additionally provide soft start and soft stop functions



Supports internal motor connection, suitable for larger size motors

Without any other external equipment, one internal soft starter can realize all functions such as soft start, operation, soft stop, etc.

- **Cost saving:** no need to purchase additional bypass contactors and bypass cables
- **Time saving:** only 6 power cables need to be connected, RST, UVW, and wiring is simple and convenient
- **Space saving:** no bypass contactor inside or outside, and the overall space required is small

### No bypass contactor required

It completely avoids possible damage to the contactor contacts caused by vibration and dust, which is advantageous in harsh applications with strong vibration or high dust and dirt.

### Start-up adaptive control technology

The triggering of SCR is controlled in a closed loop according to the power factor to achieve a smooth torque-free oscillation starting effect, reduce stress and extend the life of the load equipment.

\*For other features of online bypass, please refer to the Built-In bypass soft starter.

## ESS Series – External bypass standard wiring diagram

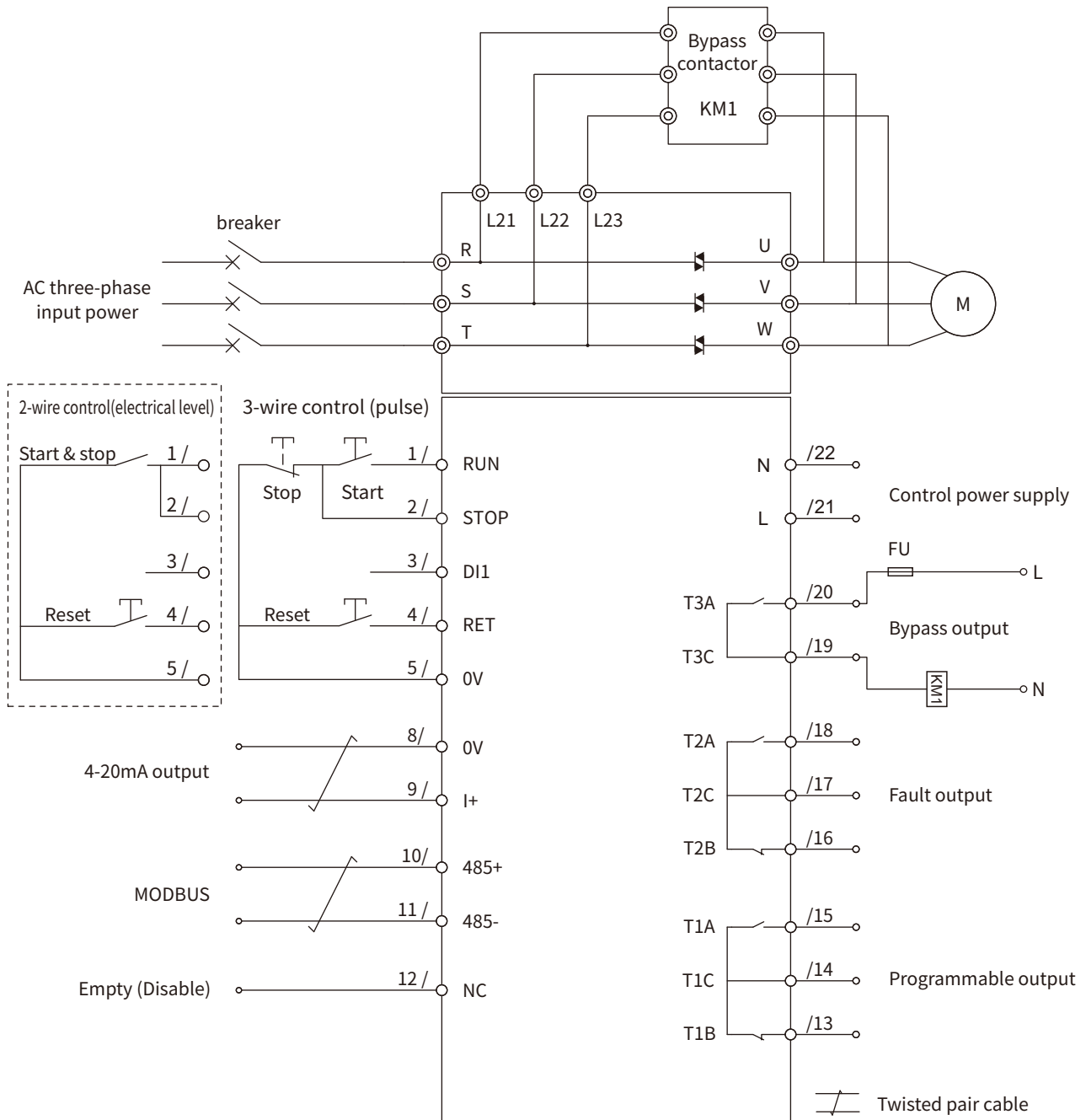

Be sure to pay attention to the following instructions when wiring:

<1> The power supply must be connected to the main circuit power supply terminals R, S, and T without phase sequence requirements. If the power supply is connected incorrectly, the soft starter will be damaged;

<2> The input and output ends of the bypass contactor must ensure the same phase sequence.

### RSE External bypass type (RSE-E) terminal description

R, S, T	Power input terminal, connect to three-phase AC power: 380~480V (-15%~+10%), 50/60Hz
U, V, W	Power output terminal, connected to three-phase induction motor/asynchronous motor
L21, L22, L23	Bypass dedicated terminal, connected to bypass contactor
1/ RUN	RUN: external control start terminal; STOP: external control stop terminal; Two-wire control: RUN and STOP can be externally controlled to start when they are short-circuited with 0V at the same time; RUN and STOP can be externally controlled to stop when they are disconnected with 0V at the same time;
2/ STOP	Three-wire control: In the case of normal STOP and 0V short-circuit: RUN and 0V short-circuit (pulse) can be externally controlled to start; STOP and 0V disconnect (pulse) can be externally controlled to stop. Note: When U090 is V1.10 and above, the STOP terminal in two-wire control can be left floating (not short-circuited with RUN)
3/ DI1	External control jog terminal: When jogging, short-circuiting JOG and 0V can realize jog control.
4/ RET	External control reset terminal: Short-circuiting RET with 0V can achieve fault reset.
5/ 0V	Control common terminal: Control terminal circuit power reference point.
8/ 0V 9/ I+	DC 4~20mA output: DC current output: 4~20mA, ≤400Ω, 20mA corresponds to 2 times the rated current of the motor. $I_{\text{Motor}} = I_{\text{Motor Rating}} * (I_{4-20\text{mA}} - 4) / 8。$
10/ 485+ 11/ 485-	Modbus RTU communication: RS485+: A, RS485-: B
12/ NC	Empty terminal: no function
13/ T1B 14/ T1C 15/ T1A	Programmable relays: T1A-T1C: Normally open contact, 5A@250VAV, 5A@30VDC T1B-T1C: Normally closed contact, 3A@250VAV, 3A@30VDC
16/ T2B 17/ T2C 18/ T2A	Fault relay: T2A-T2C: Normally open contact, 5A@250VAV, 5A@30VDC T2B-T2C: Normally closed contact, 3A@250VAV, 3A@30VDC
19/ T3C 20/ T3A	Bypass relay: T3A-T3C: Normally open contact, 8A@250VAV
21/ L 22/ N	Auxiliary (control) power supply: 220VAC input

## ESS Series – Built-In/Online bypass type standard wiring diagram

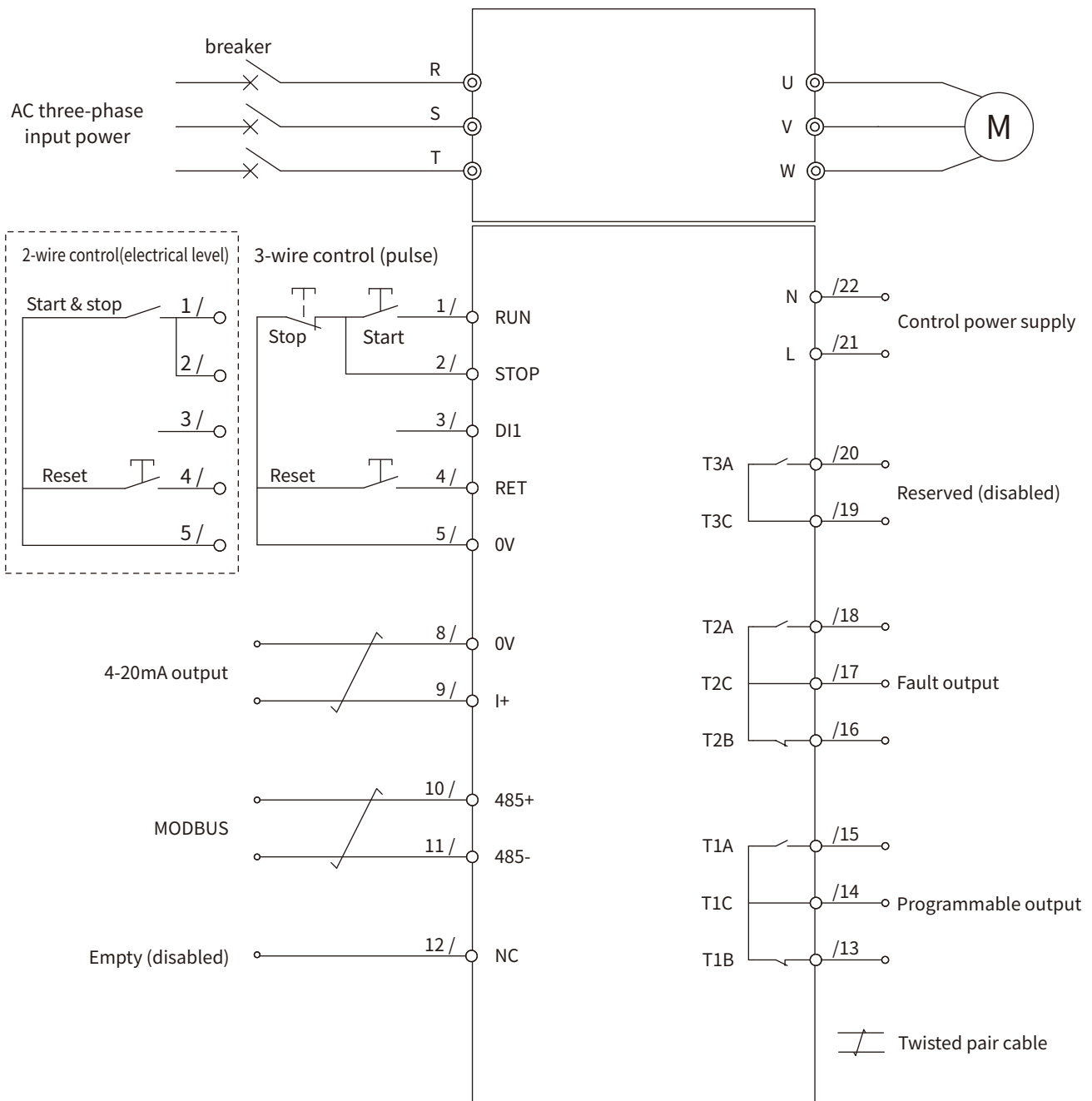

Be sure to pay attention to the following instructions when wiring:

<1> The power supply must be connected to the main circuit power supply terminals R, S, and T without phase sequence requirements. If the power supply is connected incorrectly, the soft starter will be damaged;

<2> T3A and T3C are reserved terminals and are prohibited from being used externally.

### RSE Built-In/Online bypass type (RSE-I/RSE-O) terminal description

R、S、T	Power input terminal, connect to three-phase AC power: 380~480V (-15%~+10%), 50/60Hz
U、V、W	Power output terminal, connect three-phase induction motor/asynchronous motor
1/ RUN	RUN: external control start terminal; STOP: external control stop terminal; The STOP terminal function can be set through parameter C09 to select different shutdown wiring methods: Two-wire control: RUN and STOP can be externally controlled to start when they are short-circuited with 0V at the same time; RUN and STOP can be externally controlled to stop when they are disconnected with 0V at the same time;
2/ STOP	Three-wire control: In the case of normal STOP and 0V short-circuit: RUN and 0V short-circuit (pulse) can be externally controlled to start; STOP and 0V disconnect (pulse) can be externally controlled to stop. Note: When U090 is V1.10 and above, the STOP terminal in two-wire control can be left floating (not short-circuited with RUN)
3/ DI1	Editable logic input terminal: The function of terminal DI1 can be set to emergency stop or jog through parameter C06.
4/ RET	External control reset terminal: Short-circuiting RET with 0V can achieve fault reset.
5/ 0V	Control common terminal: Control terminal circuit power reference point.
8/ 0V 9/ I+	DC 4~20mA output: DC current output: 4~20mA, $\leq 400\Omega$ , 20mA corresponds to 2 times the rated current of the motor (can be selected through C07). $I_{\text{Motor}} = I_{\text{Motor Rating}} * (I_{4-20\text{mA}} - 4) / 8。$
10/ 485+ 11/ 485-	Modbus RTU communication: RS485+: A, RS485-: B
12/ NC	Empty terminal: no function
13/ T1B 14/ T1C 15/ T1A	Programmable relays: T1A-T1C: Normally open contact, 5A@250VAV, 5A@30VDC T1B-T1C: Normally closed contact, 3A@250VAV, 3A@30VDC
16/ T2B 17/ T2C 18/ T2A	Fault relay: T2A-T2C: Normally open contact, 5A@250VAV, 5A@30VDC T2B-T2C: Normally closed contact, 3A@250VAV, 3A@30VDC
19/ T3C 20/ T3A	Reserved: Internal bypass relay control contacts, disabled.
21/ L 22/ N	Control power supply: Connect to single-phase 220VAC, 50/60Hz.



■ 2-wire system schematic diagram

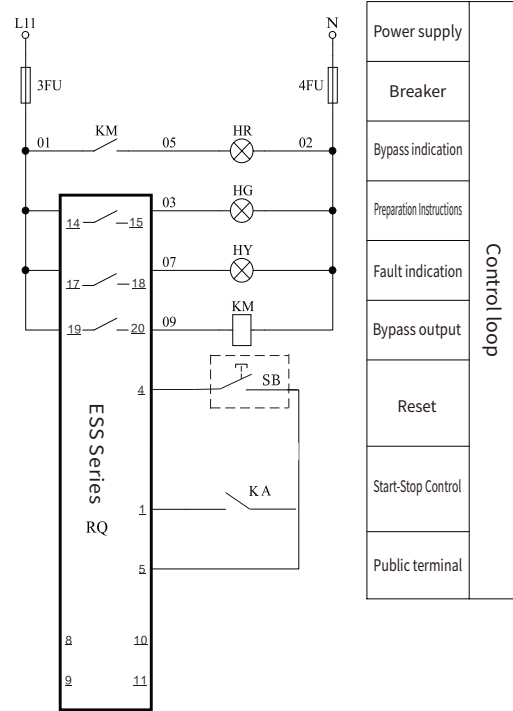
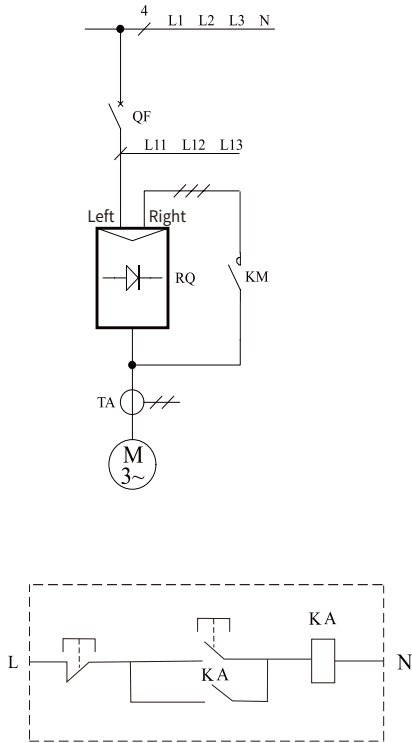

Note: 8/9 are 4-20mA analog output terminals  
10/11 are Modbus communication terminals

Or

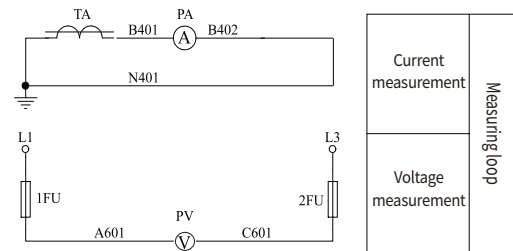
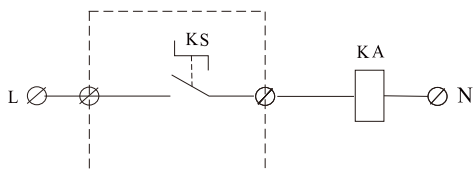



■ 2-wire system schematic diagram

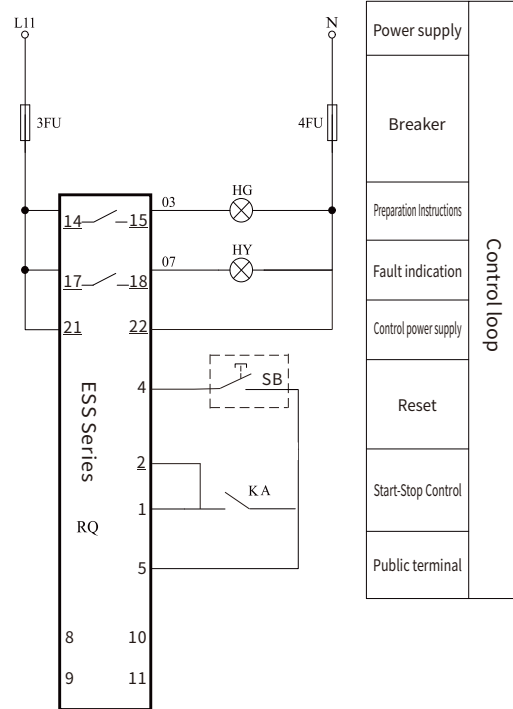
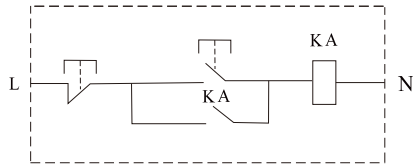
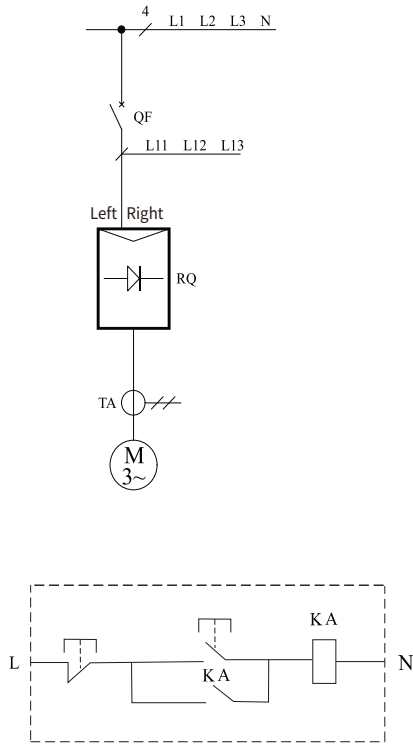

Note: 8/9 are 4-20mA analog output terminals  
10/11 are Modbus communication terminals

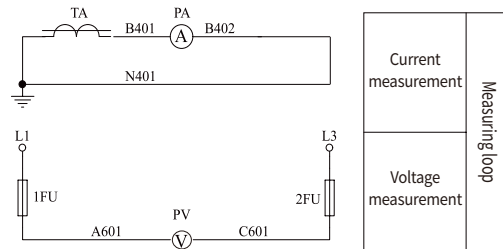
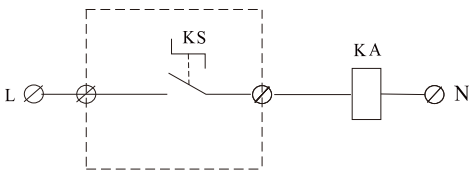

■ Illustrate

- When U090 is V1.10 or above, the soft starter's terminal 2 (STOP) can be left floating (not short-circuited with terminal 1 RUN).



## Electrim Soft Starter